

Three-terminal positive Voltage Regulator

BL78M06

FEATURES

- Output Current in Excess of 0.5A
- Output Voltage is 6V
- Internal thermal Overload protection
- Internal Short Circuit Current Limiting

PIN CONNECTION

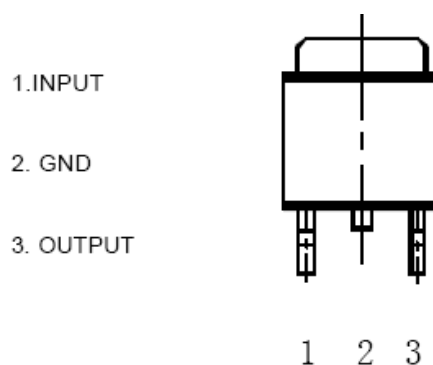

ABSOLUTE MAXIMUM RATINGS (Ta=25°C)

Characteristics	Symbol	Value	Unit
Input Voltage	V_i	35	V
Operating Temperature	T_{opr}	-40 ~ 85	°C
Storage Temperature Range	T_{stg}	-55 ~ 150	°C

ELECTRICAL CHARACTERISTICS

(unless otherwise noted, $V_i=11V, I_o=350mA, -30^{\circ}C < T_j < 85^{\circ}C, C_1=0.33\mu F, C_o=0.1\mu F$)

Characteristics	Symbol	Test conditions	Min.	Typ.	Max.	Unit
Output Voltage	V_o	$T_j=25^{\circ}C$	5.79	6	6.21	V
		$8V \leq V_i \leq 21V, I_o=5mA \sim 350mA$	5.7	6	6.3	
Load Regulation	ΔV_o	$T_j=25^{\circ}C, I_o=5mA \sim 500mA$		25	120	mV
		$T_j=25^{\circ}C, I_o=5mA \sim 200mA$		10	60	
Line Regulation	ΔV_o	$8V \leq V_i \leq 21V, I_o=200mA, T_j=25^{\circ}C$		4	100	mV
		$9V \leq V_i \leq 20V, I_o=200mA, T_j=25^{\circ}C$		2	50	
Quiescent Current	I_q	$T_j=25^{\circ}C$		4	6	mA
Quiescent Current Charge	ΔI_q	$8V \leq V_i \leq 21V, I_o=200mA$			0.8	mA
		$5mA \leq I_o \leq 350mA$			0.5	

Continues:

Characteristics	Symbol	Test conditions	Min.	Typ.	Max.	Unit
Output Noise Voltage	V_N	$10\text{Hz} \leq f \leq 100\text{kHz}$, $T_j = 25^\circ\text{C}$		40	200	μV
Dropout Voltage	V_d	$T_j = 25^\circ\text{C}$		2		V
Ripple Rejection	RR	$8\text{V} \leq V_i \leq 21\text{V}$, $f = 120\text{Hz}$, $I_o = 300\text{mA}$, $T_j = 25^\circ\text{C}$	56	80		dB
Short Circuit Current Limit	I_{sc}	$T_j = 25^\circ\text{C}$		0.8		A

APPLICATION CIRCUIT

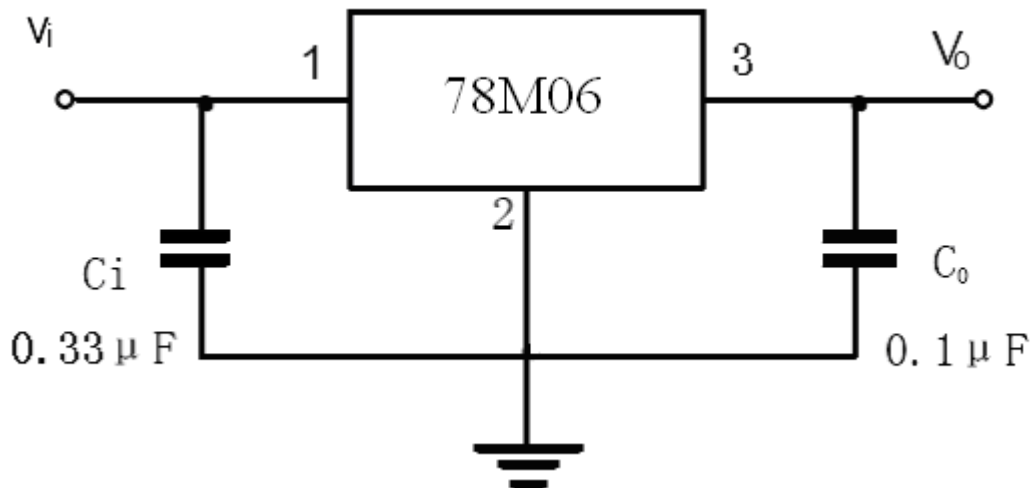

*Bypass capacitors are recommended for optimum stability and transient response and should be located as close as Possible to the regulators.

OUTLINE DRAWING

