

Linear Single Cell Li-Ion Battery Charger with Single Input Supply for Portable Applications

General Description

The RT9516 is a fully integrated low cost single-cell Li-Ion battery charger ideal for portable applications. The RT9516 is capable of being powered up from AC adapter and USB (Universal Serial Bus) port inputs. The RT9516 enters sleep mode when supplies are removed. The RT9516 optimizes the charging task by using a control algorithm including preconditioning mode, fast charge mode and constant voltage mode. The charging task will keep in constant voltage mode to hold the battery in a full charge condition. The charge current can be programmed with an external resistor. The internal thermal feedback circuitry regulates the die temperature to optimize the charge rate for all ambient temperatures. The RT9516 features 28V maximum rating voltages for VIN. The other features are under voltage protection, over voltage protection for AC adapter supply.

RT9516 also provide a booting assistant circuit which detect input source and battery connection condition and provide an output signal (ABO) for system booting.

The RT9516 is available in WDFN-8L 2x2 tiny package to achieve best solution for PCB space and total BOM cost saving considerations.

Ordering Information

RT9516□□

- Package Type
QW : WDFN-8L 2x2 (W-Type)
- Lead Plating System
G : Green (Halogen Free and Pb Free)

Note :

Richtek products are :

- ▶ RoHS compliant and compatible with the current requirements of IPC/JEDEC J-STD-020.
- ▶ Suitable for use in SnPb or Pb-free soldering processes.

Features

- 28V Maximum Rating for AC Adapter
- Internal Integrated Power MOSFETs
- AC Adapter Power Good Status Indicator
- Programmed Charging Current
- Output for Auto-Booting
- Under Voltage Protection
- Over Voltage Protection
- Thermal Feedback Optimizing Charge Rate
- RoHS Compliant and Halogen Free

Applications

- Cellular Phones
- Digital Cameras
- PDAs and Smart Phones
- Probable Instruments

Pin Configurations

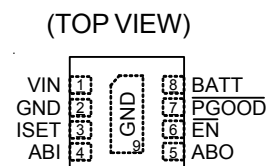

WDFN-8L 2x2

Marking Information

For marking information, contact our sales representative directly or through a Richtek distributor located in your area.

Typical Application Circuit

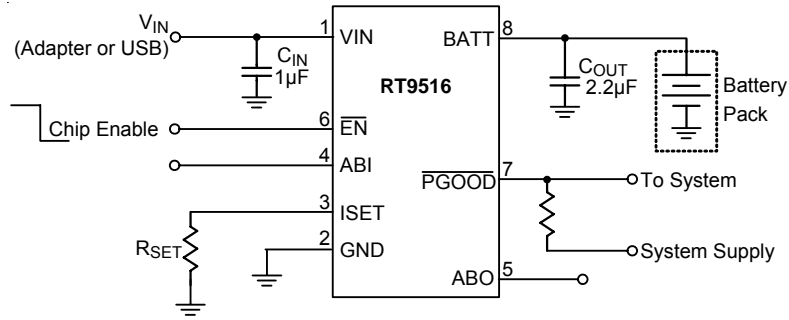

Function Block Diagram

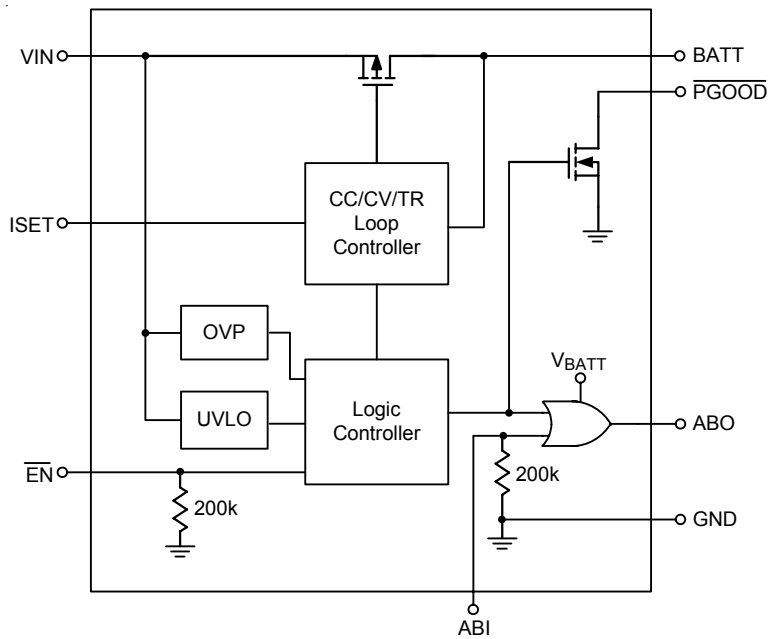

Flow Chart

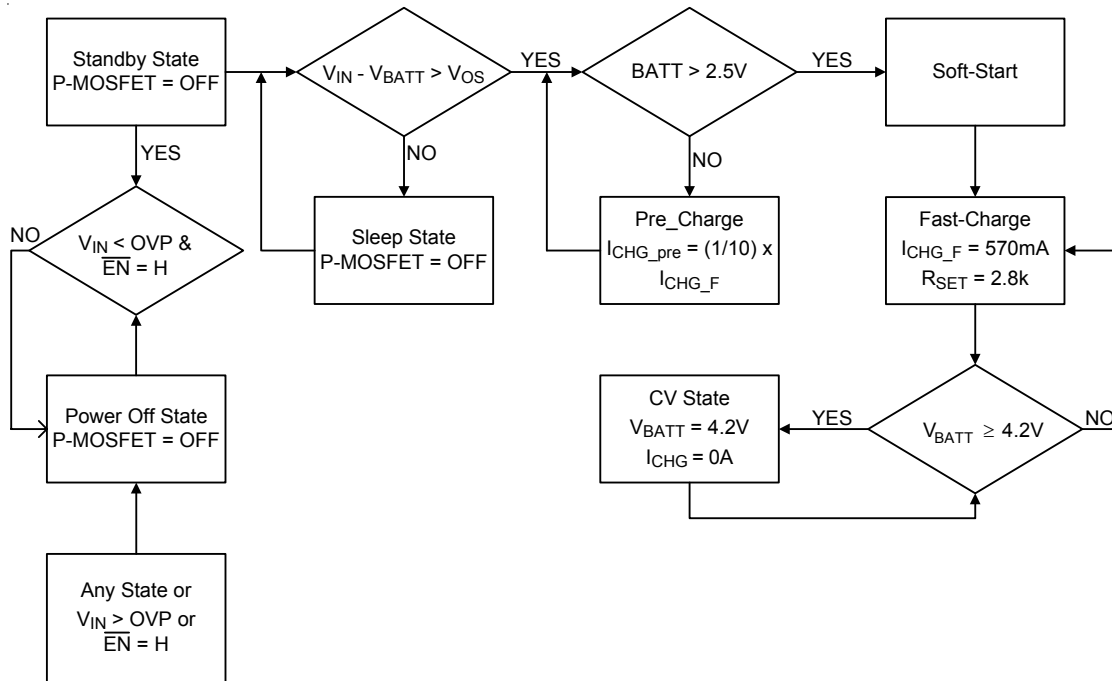

Functional Pin Description

Pin No.	Pin Name	Pin Function
1	VIN	Input Power Source. The VIN can withstand up to 28V input.
2, 9 (Exposed Pad)	GND	Power Ground. The exposed pad must be soldered to a large PCB and connected to GND for maximum power dissipation.
3	ISET	Charge Current Set Point.
4	ABI	Auto-Booting External Input. ABI is pulled to GND through an internal 200kΩ resistor.
5	ABO	Auto-Booting Logic Output.
6	EN	Charge Enable (Active Low). With internal 200kΩ pull low resistor.
7	PGOOD	PGOOD pin connect to VIN with 10Ω N-MOSFET as power good condition.
8	BATT	Battery Charge Current Output.

Absolute Maximum Ratings (Note 1)

- Supply Voltage, V_{IN} ----- -0.3V to 28V
- Other Pins ----- -0.3V to 28V
- Power Dissipation, $P_D @ T_A = 25^\circ C$
 WDFN-8L 2x2 ----- 0.606W
- Package Thermal Resistance (Note 2)
 WDFN-8L 2x2, θ_{JA} ----- 165°C/W
- Lead Temperature (Soldering, 10 sec.) ----- 260°C
- Junction Temperature ----- 150°C
- Storage Temperature Range ----- -65°C to 150°C
- ESD Susceptibility (Note 3)
 HBM (Human Body Mode) ----- 2kV
 MM (Machine Mode) ----- 200V

Recommended Operating Conditions (Note 4)

- Supply Voltage, V_{IN} ----- 4.5V to 6V
- Junction Temperature Range ----- -40°C to 125°C
- Ambient Temperature Range ----- -40°C to 85°C

Electrical Characteristics

($V_{IN} = 5V$, $V_{BATT} = 4V$, $T_A = 25^\circ C$, unless otherwise specified)

Parameter		Symbol	Test Conditions	Min	Typ	Max	Unit
Offset Voltage ($V_{IN}-V_{BATT}$) Rising		V_{OS-R}		--	90	150	mV
Offset Voltage ($V_{IN}-V_{BATT}$) Falling		V_{OS-F}		10	50	--	mV
VIN Standby Current		I_{STBY}	$V_{BATT} = 4.5V$	--	300	500	μA
Over Voltage Protection Threshold		V_{OVP}		6.5	7	7.5	V
Battery Regulation Voltage Regulation		V_{REG}	$T_A = 0$ to $85^\circ C$	4.158	4.2	4.242	V
BATT Sleep Leakage Current		I_{SLEEP}		--	1	10	μA
VIN Power MOSFET $R_{DS(ON)}$			$I_{BATT} = 0.5A$	--	0.4	0.8	Ω
ISET Set Voltage (Fast Charge)		V_{ISET}		--	1.4	--	V
Charge Current Accuracy		I_{CHG}	$R_{SET} = 2.8k$	524	570	616	mA
BATT Pre-Charge Threshold		V_{PCHG_BATT}	BATT Rising	2.3	2.5	2.7	V
Pre-Charge Current		I_{PCHG}		4	10	15	%
\overline{EN} Threshold Voltage	Logic-High	V_{IH}		1.5	--	--	V
	Logic-Low	V_{IL}		--	--	0.4	V
Enable Pull Low Resistor				--	200	--	k Ω
Thermal Regulation				--	115	--	$^\circ C$
PGOOD Pull Down Voltage		V_{PGOOD}	5mA	--	65	--	mV
ABI Threshold Voltage	Logic-High	V_{IH}		1.5	--	--	V
	Logic-Low	V_{IL}		--	--	0.4	V
ABI Pull Low Resistor				--	200	--	k Ω
ABO Pull Down Voltage			5mA	--	100	--	mV

- Note 1.** Stresses listed as the above “Absolute Maximum Ratings” may cause permanent damage to the device. These are for stress ratings. Functional operation of the device at these or any other conditions beyond those indicated in the operational sections of the specifications is not implied. Exposure to absolute maximum rating conditions for extended periods may remain possibility to affect device reliability.
- Note 2.** θ_{JA} is measured in the natural convection at $T_A = 25^\circ\text{C}$ on a low effective thermal conductivity single layer test board of JEDEC 51-3 thermal measurement standard.
- Note 3.** Devices are ESD sensitive. Handling precaution is recommended.
- Note 4.** The device is not guaranteed to function outside its operating conditions.

Typical Operating Characteristics

BATT Pre-Charge Power On

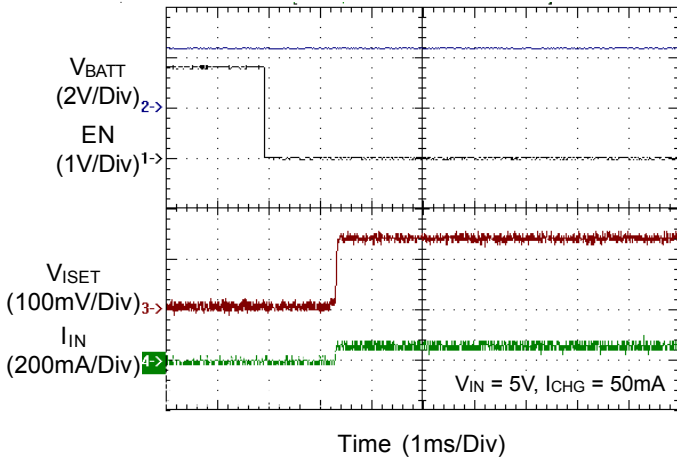

BATT Fast-Charge Power On

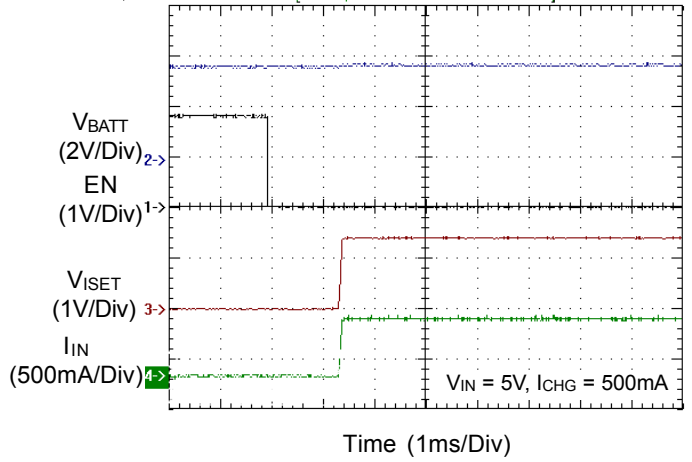

Power Off from ACIN

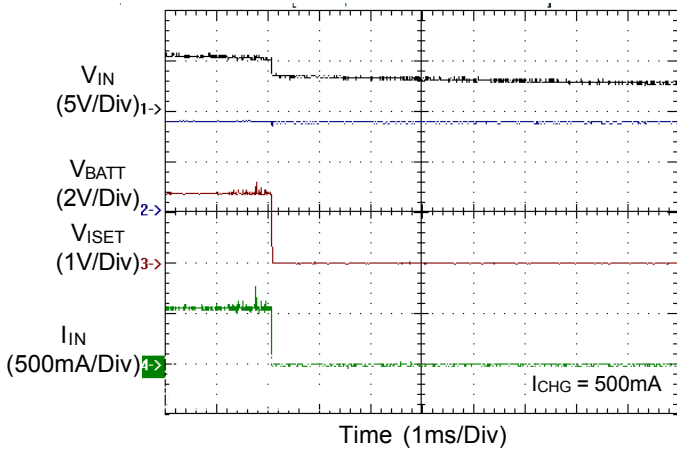

Power Off From EN

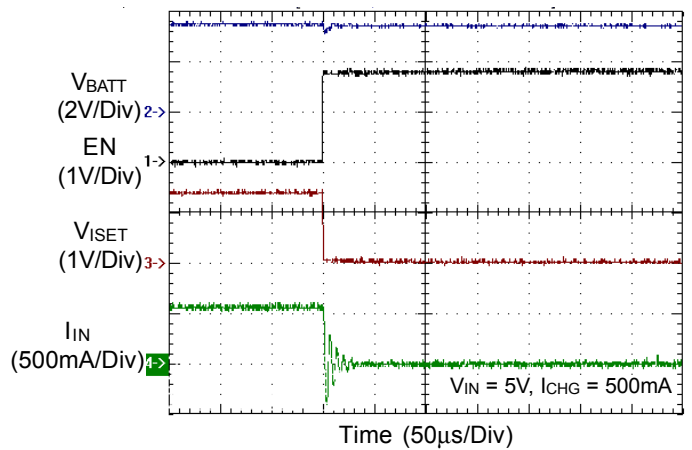

Input Standby Current vs. Input Voltage

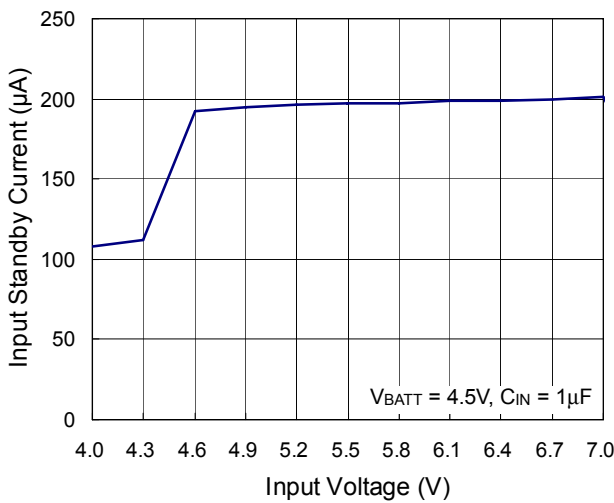

Input Shutdown Current vs. Input Voltage

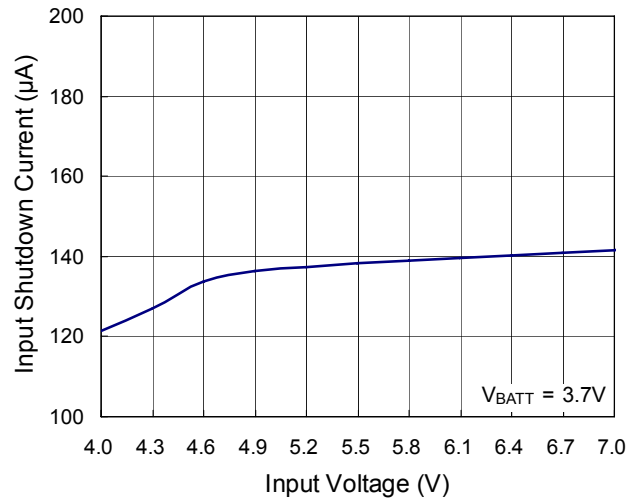

Charge Current vs. R_{SET}

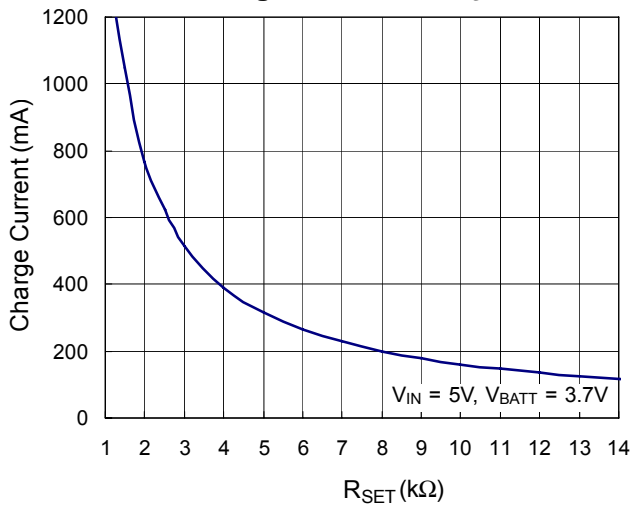

Input OVP vs. Temperature

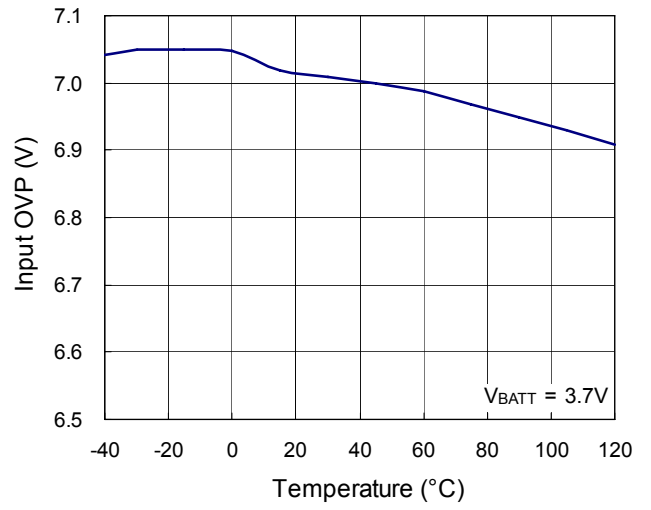

Battery Regulation Voltage vs. Temperature

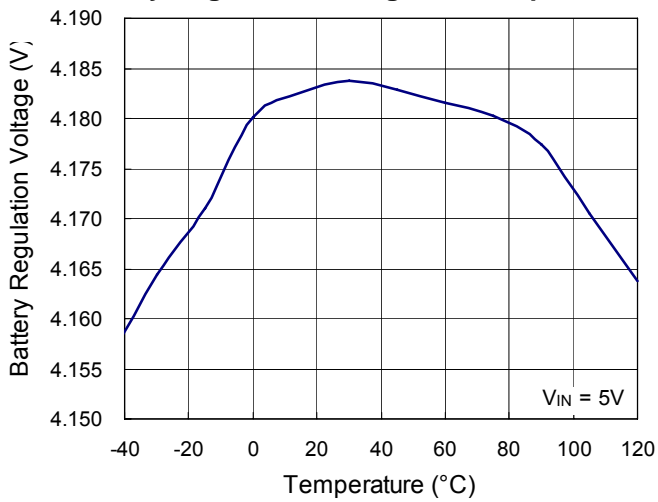

Applications Information

The RT9516 is a fully integrated low cost single-cell Li-Ion battery charger with a constant current (CC mode) or a constant voltage (CV mode). The CC mode current is set with the external resistor R_{SET} and the CV mode voltage is fixed at 4.2V. If the battery voltage is below a typical 2.5V pre-charge threshold, the RT9516 charges the battery with a trickle current until the battery voltage rises above the pre-charge threshold. The RT9516 is capable of being powered up from AC adapter and USB (Universal Serial Bus) port inputs.

ACIN Over-Voltage Protection

The input voltage is monitored by the internal comparator. The OVP threshold is set at 7V (typ.). When the input voltage exceeds the threshold, the controller outputs a logic signal to turn off the power P-MOSFET to prevent the high input voltage from damaging the electronics in the handheld system. However, AC input voltage over 28V still leads the RT9516 to damage. When the input overvoltage condition is removed, the controller will enable the output by running through the soft-start.

Charger Enable Input

\overline{EN} is an active-low logic input to enable the charger. Drive the \overline{EN} pin to low or leave it floating to enable the charger. This pin has a 200k Ω internal pull down resistor. So when left floating, the input is equivalent to logic low. Drive this pin to high to disable the charger.

Battery Charge Profile

The RT9516 charges a Li-ion battery with a constant current (CC) or a constant voltage (CV). The constant current of ISET is set with the external resistor R_{SET} and the constant voltage is fixed at 4.2V. If the battery voltage is below a typical 2.5V trickle-charge threshold, the RT9516 charges the battery with a trickle current until the battery voltage rises above the trickle charge threshold. When the battery voltage reaches 4.2V, the charger enters a CV mode and regulates the battery voltage at 4.2V to fully charge the battery without the risk of over charge.

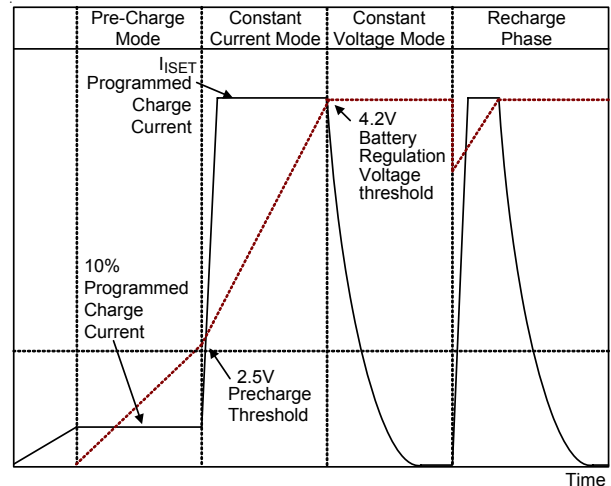

Figure 1

a. Battery Pre-Charge Current

During a charge cycle, if the battery voltage is below the pre-charge threshold, the RT9516 applies a pre-charge mode to the battery. This feature revives deeply discharged cells and protects battery life. The internally determined pre-charge rate of the RT9516 is 10% of the constant charge current.

b. Battery Fast-Charge Current

The RT9516 offers ISET pin to determine the charge current. By an external resistor connected between the ISET and GND. The charge current can be calculated by the following equation :

$$I_{charge} = K_{SET} \frac{V_{SET}}{R_{SET}}$$

$$K_{SET} = 1140; V_{SET} = 1.4(\text{typ.})$$

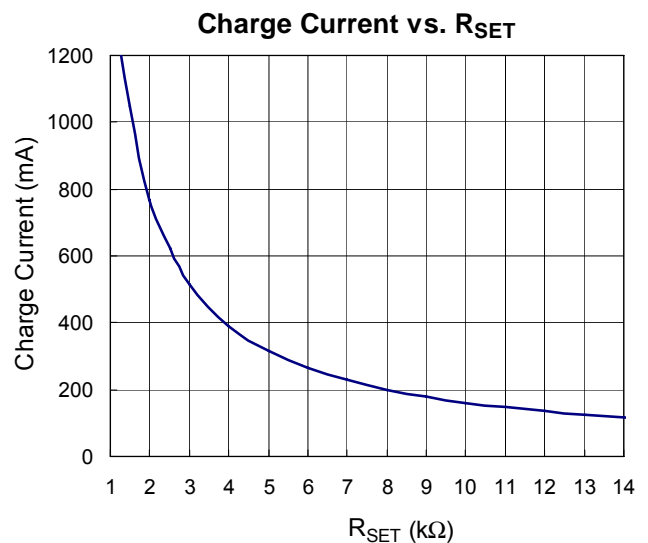

Figure 2

c. Battery Voltage Regulation (CV Mode)

The battery voltage regulation feedback is through the BATT pin. The RT9516 monitors the battery voltage between the BATT and GND pins. When battery voltage is close to battery regulation voltage threshold, the voltage regulation phase begins and the charging current begins to taper down. When battery voltage is over battery regulation voltage threshold and charge mode stops, the RT9516 still monitors the battery voltage. Charge current is resumed when the battery voltage under battery regulation voltage threshold.

Sleep Mode

The RT9516 enters the sleep mode if both AC and USB are removed from the input. This feature prevents draining the battery during the absence of input supply.

Power Good

The open-drain output pin is used to indicate the input voltage status. The $\overline{\text{PGOOD}}$ output asserts low when $V_{\text{IN}} > 4.25\text{V}$ and $(V_{\text{IN}} - V_{\text{BATT}}) > 40\text{mV}$. These $\overline{\text{PGOOD}}$ pin can be used to drive LED or communicate to the host processor. Note that ON indicates the open-drain transistor is turned on and LED is bright.

Auto-Booting

The RT9516 has an internal “OR” gate that generates an enable signal for system booting. The battery supplies power to the “OR” gate, the RT9516 will keep BATT pin voltage to supply the “OR” gate function when the battery isn connected at BATT pin. The first input is the AC_PG and the second input is an external signal (ABI). When the $(V_{\text{IN}} - V_{\text{BATT}}) > 90\text{mV}$, the AC_PG signal is high. The ABI signal is driven by an external system, when external signal is floating, the ABI has an internal pull low resistor.

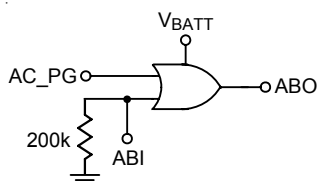

Figure 3

Temperature Regulation and Thermal Protection

In order to maximize charge rate, the RT9516 features a junction temperature regulation loop. If the power dissipation of the IC results in a junction temperature that is greater than the thermal regulation threshold (115°C), the RT9516 throttles back on the charge current in order to maintain a junction temperature around the thermal regulation threshold (115°C). The RT9516 monitors the junction temperature, T_J , of the die and disconnects the battery from the input if T_J exceeds 115°C. This operation continues until junction temperature falls below thermal regulation threshold (115°C by the hysteresis level. This feature prevents the maximum power dissipation from exceeding typical design conditions.

Selecting the Input and Output Capacitors

In most applications, a high-frequency decoupling capacitor on the input.(1μF ceramic capacitor), placed in close proximity to the input works well. In some applications depending on the power supply characteristics and cable length, it may be necessary to add an additional 10μF ceramic capacitor to the input. The RT9516 requires a small output capacitor for loop stability. A 1μF ceramic capacitor placed between the BATT pin and GND is typically sufficient.

Thermal Conderations

The maximum power dissipation depends on the thermal resistance of IC package, PCB layout, the rate of surroundings airflow and temperature difference between junction to ambient. The maximum power dissipation can be calculated by following formula :

$$P_{D(\text{MAX})} = (T_{J(\text{MAX})} - T_A) / \theta_{JA}$$

Where $T_{J(\text{MAX})}$ is the maximum operation junction temperature, T_A is the ambient temperature and the θ_{JA} is the junction to ambient thermal resistance.

For recommended operating conditions specification of RT9516, where $T_{J(\text{MAX})}$ is 125°C and T_A is the operated ambient temperature. The junction to ambient thermal resistance θ_{JA} for WDFN-8L 2x2 package is 165°C/W on the standard JEDEC 51-3 single-layer thermal test board.

The maximum power dissipation at $T_A = 25^\circ\text{C}$ can be calculated by following formula :

$$P_{D(\text{MAX})} = (125^\circ\text{C} - 25^\circ\text{C}) / (165^\circ\text{C} / \text{W}) = 0.606\text{W}$$

for WDFN-8L 2x2 package

The maximum power dissipation depends on operating ambient temperature for fixed $T_{J(\text{MAX})}$ and thermal resistance θ_{JA} . For RT9516 package, the Figure 4 of derating curves allows the designer to see the effect of rising ambient temperature on the maximum power allowed.

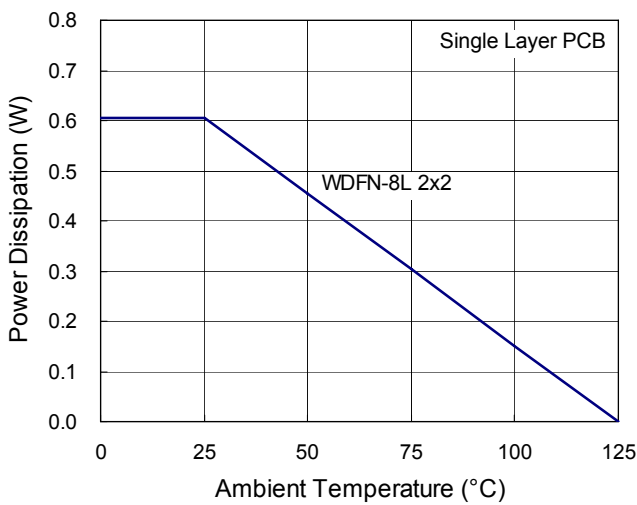

Figure 4. Derating Curves for RT9516 Package

Layout Consideration

The RT9516 is a fully integrated low cost single-cell Li-Ion battery charger ideal for portable applications. Careful PCB layout is necessary. For best performance, place all peripheral components as close to the IC as possible. A short connection is highly recommended. The following guidelines should be strictly followed when designing a PCB layout for the RT9516.

- ▶ Input capacitor should be placed close to IC and connected to ground plane. The trace of input in the PCB should be placed far away from the sensitive devices or shielded by the ground.
- ▶ The GND and exposed pad should be connected to a strong ground plane for heat sinking and noise protection.
- ▶ The connection of R_{SET} should be isolated from other noisy traces. The short wire is recommended to prevent EMI and noise coupling.
- ▶ Output capacitor should be placed close to the IC and connected to ground plane to reduce noise coupling.

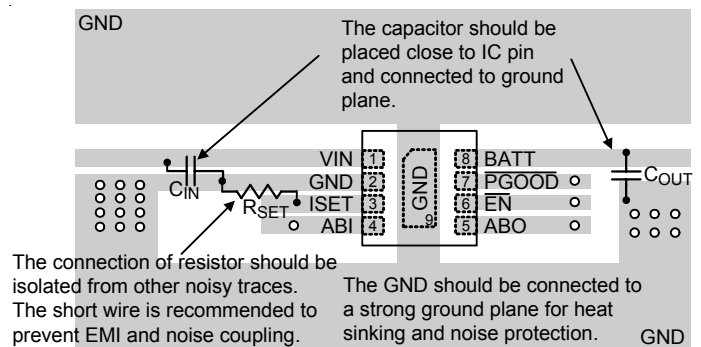
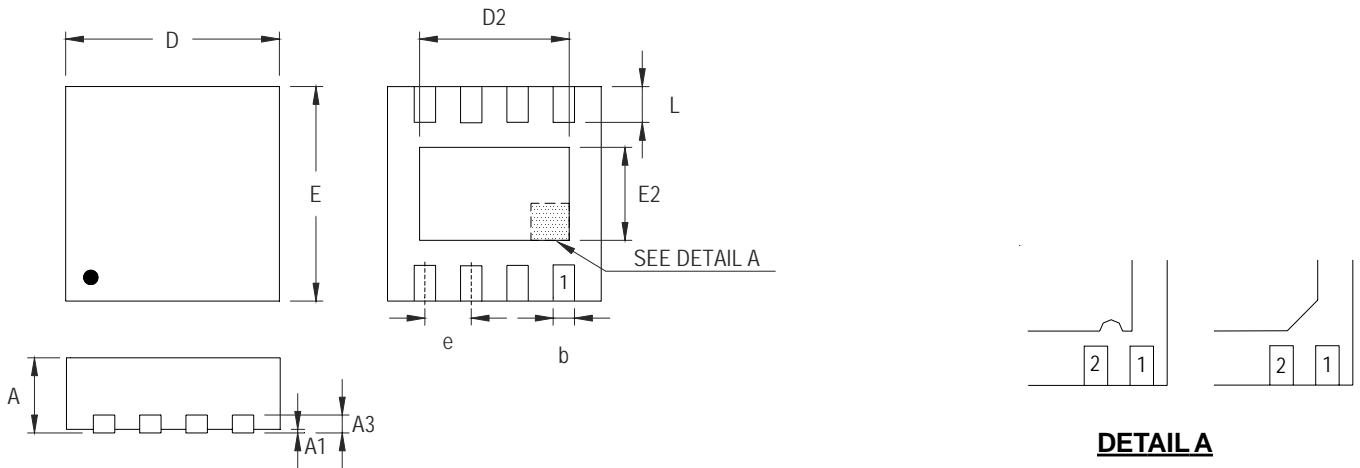

Figure 5. PCB Layout Guide

Outline Dimension



DETAIL A
Pin #1 ID and Tie Bar Mark Options

Note : The configuration of the Pin #1 identifier is optional, but must be located within the zone indicated.

Symbol	Dimensions In Millimeters		Dimensions In Inches	
	Min	Max	Min	Max
A	0.700	0.800	0.028	0.031
A1	0.000	0.050	0.000	0.002
A3	0.175	0.250	0.007	0.010
b	0.200	0.300	0.008	0.012
D	1.950	2.050	0.077	0.081
D2	1.000	1.250	0.039	0.049
E	1.950	2.050	0.077	0.081
E2	0.400	0.650	0.016	0.026
e	0.500		0.020	
L	0.300	0.400	0.012	0.016

W-Type 8L DFN 2x2 Package

Richtek Technology Corporation

Headquarter
5F, No. 20, Taiyuen Street, Chupei City
Hsinchu, Taiwan, R.O.C.
Tel: (8863)5526789 Fax: (8863)5526611

Richtek Technology Corporation

Taipei Office (Marketing)
5F, No. 95, Minchiuan Road, Hsintien City
Taipei County, Taiwan, R.O.C.
Tel: (8862)86672399 Fax: (8862)86672377
Email: marketing@richtek.com

Information that is provided by Richtek Technology Corporation is believed to be accurate and reliable. Richtek reserves the right to make any change in circuit design, specification or other related things if necessary without notice at any time. No third party intellectual property infringement of the applications should be guaranteed by users when integrating Richtek products into any application. No legal responsibility for any said applications is assumed by Richtek.